

Front of House / Luggage trolleys

# Vesuvio 1100

Gruppen-Gepäckwagen – ein toller Klassiker



## Standard Ausrüstung

- Integrierte Garderobenstange
- Boden mit Teppich (verschiedene Farben)
- Nicht-markierender Rundum-Stoßfänger aus flexiblem Material
- 2 Bockrollen und 2 Lenkrollen Ø200 mm, sehr leises, nicht-markierendes Gummimaterial

# Optionen

- Personalisierung der Kronen mit dem Logo Ihrer Einrichtung
- Zentrale Bremse
- Schwenkrollen mit Bremse
- luftbereifte Rollen Ø 230mm
- Schutzabdeckung (Möglichkeit der Personalisierung)
- Motorisierung

VESUVIO 1100

# Ausführungen

## Anodisation



Silver



Gold mat



Black mat

## Carpet



Blue



Red



Black



Brown

## Woven vinyl



Graphite



Sand



Stone

# Abmessungen

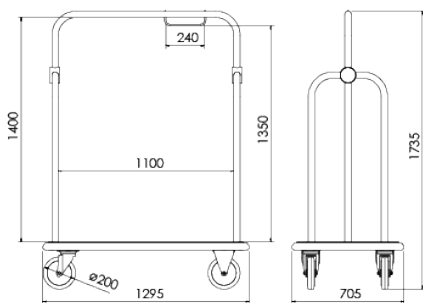

## VESUVIO 1100

### Overall dimensions

Width	Depth	Height	Wheels Ø
1295 mm	705 mm	1735 mm	200 mm

### Inside dimensions

Width	Height
1100 mm	1350 mm