

Food & Beverage / Room service / Minibar restocking trolleys

e-Lugano 800

Ergonomic motorized mini-bar restocking



Standard equipment

- Anodised aluminium frame
- 1 compartment for small products with lid
- 3 drawers (depth 100mm) on telescopic rails, height adjustable
- Doors (opening up to 270°) with lock
- 4 swivelling wheels Ø125mm with non-marking polyamide layer
- 4 swivelling corner pads for protection
- 1 horizontal steering handle

Technical info

- Net weight: 75 kg
- Load capacity: 250 kg
- Working autonomy: at least 1 working day
- Charging time: 7 hours
- Power: 240W
- Battery: AGM 12v
- Maximum forward speed: 6 km/h
- Maximum reverse speed: 3 km/h
- CE certification

Options

- Linear dividers for small products compartment and drawer
- Drawer instead of small products compartment (590 x 342 x 100 mm)
- Non-slip carpet
- Identification holder
- Hook
- Sliding tray

E-LUGANO 800

Finishes

Compact



Caviar



Wenge



Almond



Antique oak

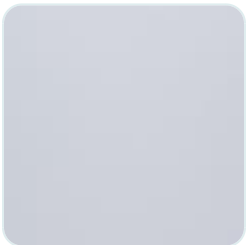

Light grey



Nappa black leather



Black ash



Buffalo

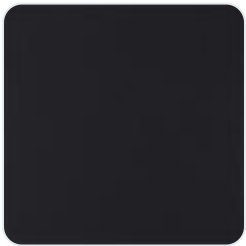

Infinity black (fingerprint-free)

Anodisation



Natural



Champagne



Bronze



Black

Dimensions

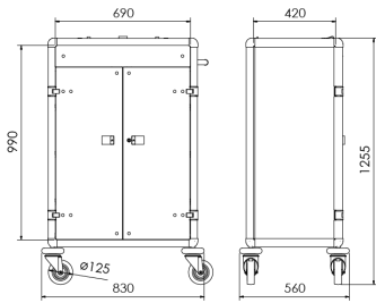

E-LUGANO 800

Overall dimensions

Width	Depth	Height	Wheels Ø
830 mm	560 mm	1255 mm	125 mm

Inside dimensions

Width	Depth
690 mm	420 mm